



Electrak[®] 1 SP – Technical Features



Standard Features

- Compact and lightweight
- Integrated 10 kOhm potentiometer feedback
- Corrosion resistant housing
- Self-locking acme screw drive system
- Maintenance free
- Internally restrained extension tube
- Ideal for replacement of comparable size pneumatic and hydraulic cylinders

General Specifications

Screw type	acme
Nut type	acme
Manual override	no
Anti-rotation	no
Static load holding brake	no (self-locking)
Safety features	motor auto reset thermal switch
Electrical connections	flying leads with connector to the motor, cable with flying leads to the potentiometer
Compliances	CE

Compatible Controls

Contact customer support at www.thomsonlinear.com/cs

Electrak[®] 1 SP– Technical Specifications

Mechanical Specifications		
Max. static load ⁽¹⁾	[N (lbf)]	1300 (300)
Max. dynamic load (Fx)	[N (lbf)]	
SPxx -09A04		110 (25)
SPxx -09A08		225 (50)
SPxx -17A08		340 (75)
SPxx -17A16		340 (75)
Speed @ no load/max. load	[mm/s (in/s)]	
SPxx -09A04		78/64 (3.1/2.5)
SPxx -09A08		39/29 1.5/1.1)
SPxx -17A08		21/16 (0.8/0.6)
SPxx -17A16		10/8 (0.4/0.3)
Min. ordering stroke (S) length	[in]	1
Max. ordering stroke (S) length	[in]	8
Ordering stroke length increments	[in]	1
Operating temperature limits	[°C (F)]	- 25 – 65 (- 13 – 150)
Full load duty cycle @ 25 °C (77 °F)	[%]	25
End play, maximum	[mm (in)]	0.9 (0.04)
Restraining torque	[Nm (lbf-in)]	2.3 (1.7)
Protection class - static		IP66
Salt spray resistance	[h]	96

(1) Max. static load at fully retracted stroke

Electrical Specifications		
Available input voltages ⁽¹⁾	[Vdc]	12, 24
Input voltage tolerance	[%]	± 10
Current draw @ no load/max. load	[A]	
SP12 -09A04		0.8/3.8
SP12 -09A08		0.8/4.4
SP12 -17A08		0.8/4.1
SP12 -17A16		0.8/3.8
SP24 -09A04		0.4/1.6
SP24 -09A08		0.4/2.0
SP24 -17A08		0.4/1.9
SP24 -17A16		0.4/1.6
Motor leads length	[mm (in)]	100 (4)
Motor leads cross section	[mm ² (AWG)]	1 (18)
Potentiometer cable length	[mm (in)]	635 (25)
Potentiometer cable diameter	[mm (in)]	5 (0.2)
Pot. cable leads cross section	[mm ² (AWG)]	0.5 (20)

Electrak[®] 1 SP – Performance Diagrams

Speed and Current vs. Load 12 Vdc Models

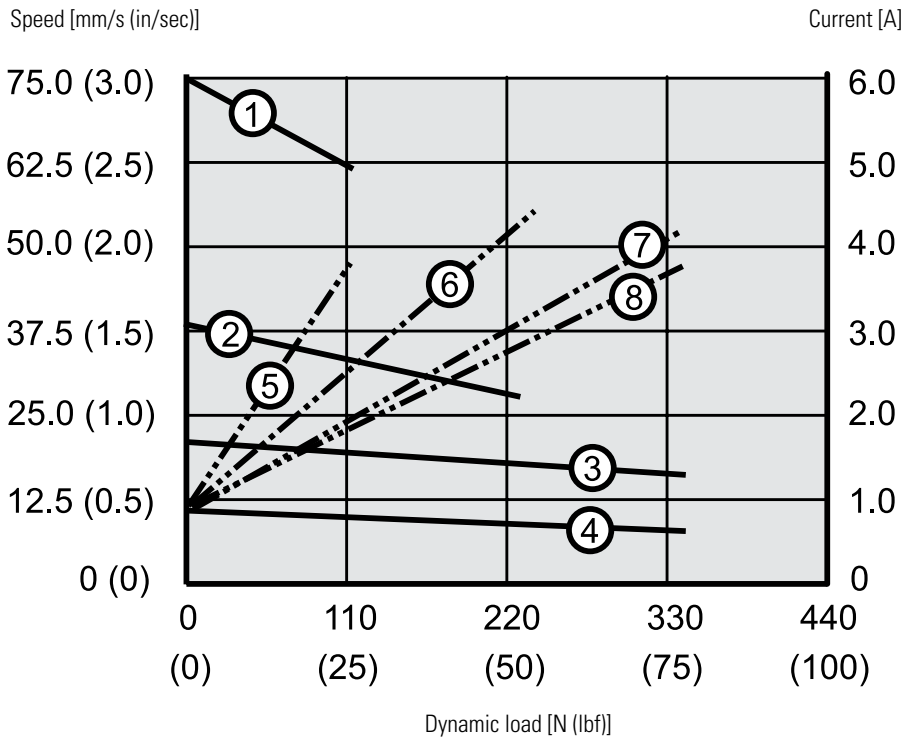

Speed

- 1: SP12-09A04 (110 N (25 lbf))
- 2: SP12-09A08 (225 N (50 lbf))
- 3: SP12-17A08 (340 N (75 lbf))
- 4: SP12-17A16 (340 N (75 lbf))

Current

- 5: SP12-09A04 (110 N (25 lbf))
- 6: SP12-09A08 (225 N (50 lbf))
- 7: SP12-17A08 (340 N (75 lbf))
- 8: SP12-17A16 (340 N (75 lbf))

Speed and Current vs. Load 24 Vdc Models

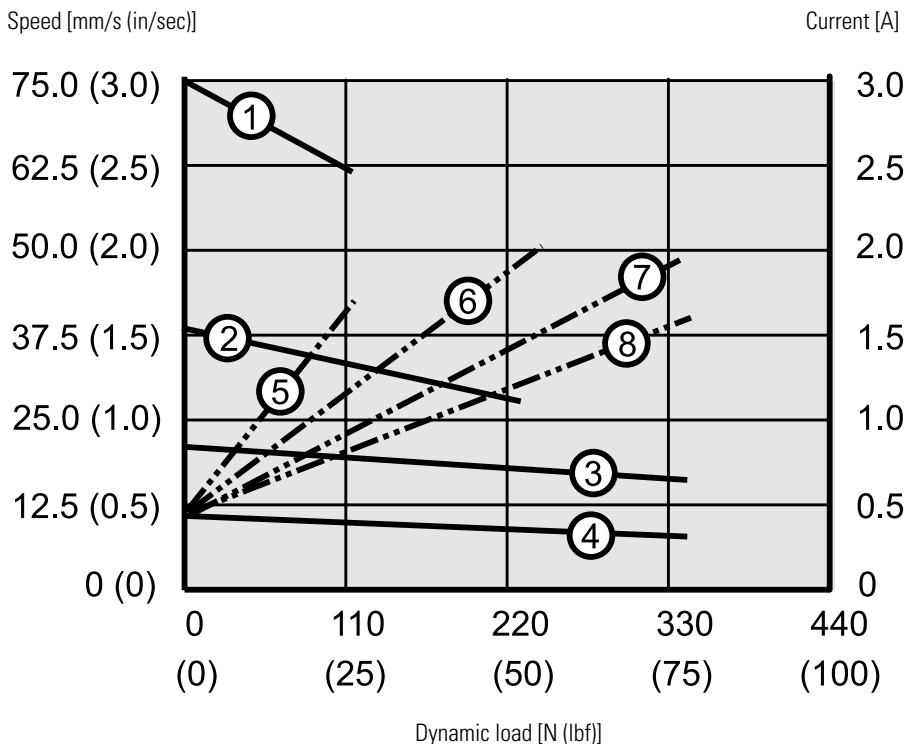

Speed

- 1: SP24-09A04 (110 N (25 lbf))
- 2: SP24-09A08 (225 N (50 lbf))
- 3: SP24-17A08 (340 N (75 lbf))
- 4: SP24-17A16 (340 N (75 lbf))

Current

- 5: SP24-09A04 (110 N (25 lbf))
- 6: SP24-09A08 (225 N (50 lbf))
- 7: SP24-17A08 (340 N (75 lbf))
- 8: SP24-17A16 (340 N (75 lbf))



Electrak[®] 1 SP – Ordering Key

Ordering Key						
1	2	3	4	5	6	7
SP12	C	09A04-	04	-C	A	A
1. Model and input voltage SP12 = Electrak 1, potentiometer feedback, 12 Vdc SP24 = Electrak 1, potentiometer feedback, 24 Vdc			5. Connector option -C = Packard Electric Pac-Con -J = AMP Superseal 5 pin			
2. CE compliance N = no C = yes			6. Front adapter option A = Cross hole 0.25 inch T = Cross hole 8 mm V = Female thread 1/4 inch-28 W = Female thread M8			
3. Dynamic load capacity, screw type and maximum speed 09A04- = 110 N (25 lbf), acme, 75 mm/s (3 in/s) 09A08- = 225 N (50 lbf), acme, 45 mm/s (1,8 in/s) 17A08- = 340 N (75 lbf), acme, 26 mm/s (1 in/s) 17A16- = 340 N (75 lbf), acme, 16 mm/s (0,6 in/s) ⁽¹⁾			7. Rear adapter option A = Cross hole 0.25 inch B = Cross hole 8 mm			
4. Ordering stroke length 01 = 1.2 inch (30.4 mm) 02 = 2.3 inch (58.7 mm) 03 = 3.5 inch (86.8 mm) 04 = 4.6 inch (115.1 mm) 05 = 5.8 inch (143.2 mm) 06 = 6.9 inch (171.5 mm) 08 = 9.2 inch (227.9 mm)			(1) Not possible in combination with 6 or 8 inch stroke.			

Electrak[®] 1 SP – Electrical Connections

Standard		
Actuator supply voltage	[Vdc]	
SP12		12
SP24		24
Potentiometer type		wire-wound
Potentiometer resistance	[kOhm]	10
Potentiometer max. input voltage	[Vdc]	32
Potentiometer max. power	[W]	1.5
Resistance tolerance	[%]	5
Potentiometer linearity	[%]	± 0.25
Potentiometer output resolution	[ohm/mm]	
SPxxxxxxx01(02)		94.5
SPxxxxA04(08)03(04)		47.2
SPxxxxA1603(04, 05)		63.0
SPxxxxA04(08)05(06, 08)		31.5

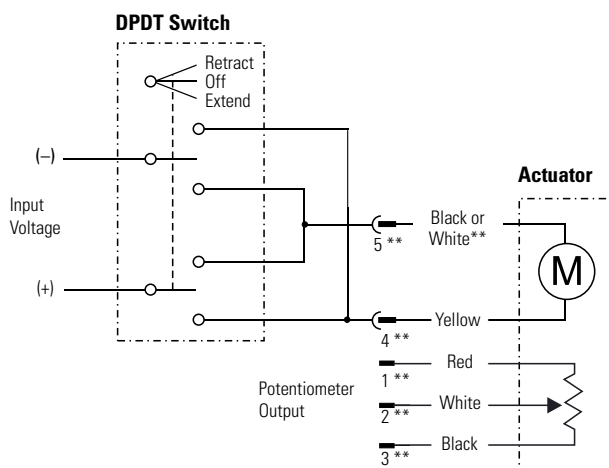

** Black for 12 Vdc supply voltage
 White for 24 Vdc supply voltage
 ** If equipped with AMP Superseal connector

Connect the yellow lead (pin 4 if connector) to positive and black or white (pin 5 if connector) to negative to extend the actuator. Change polarity to retract the actuator. The potentiometer output has 0 ohm between white (pin 2 if connector) and red (pin 1 if connector) when the actuator is fully retracted. The actuator should be protected from overload conditions by a customer-provided fuse in the circuit (6 A for 12 Vdc and 3 A for 24 Vdc).