

# POMPE A PISTONI AD ASSE INCLINATO BENT AXIS PISTON PUMPS

**CODICE FAMIGLIA**  
FAMILY CODE

**614080**

**"HDS"**

Flangia/Flange

SAE-C

**"MDS"**

Albero/Shaft

14T 12/24

Cilin./Displ.

47-55-64-80

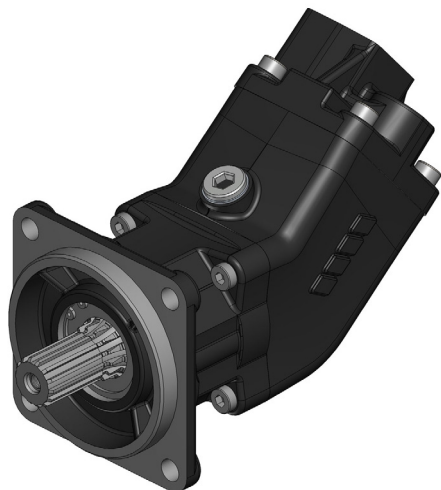

99740060010

Fluido idraulico Fluid	Minerale o sintetico compatibile con guarnizioni: Mineral or synthetic compatible with the following seals: FKM, FPM, HNBR				
Viscosità cinematica consigliata Kinematic viscosity suggested	T media ambiente (°C) Average ambient temp. (°C)	< -40	-40 ÷ 10	10 ÷ 35	> 35
	VG (cSt = mm <sup>2</sup> /s)	16	22	32	46
Viscosità cinematica ottimale di esercizio Optimale kinematic viscosity		VG = 10 cSt ÷ 100 cSt			
Viscosità cinematica max consentita all'avviamento Max kinematic viscosity suggested at the start-up		VG = 750 cSt			
Indice di viscosità consigliato Viscosity index suggested	VI > 100	Temperatura di esercizio Working temperature -15°C ÷ 140°C			
Grado di filtrazione Oil filtering		> 200 bar: 10 µm < 200 bar: 25 µm			
Pres. di aspirazione Inlet pressure		0,85 ÷ 2 bar assoluti/absolut			
Senso di rotazione Pump rotation		Unidirezionale (Dx o Sx) Unidirectional (Right or Left)			
Verificare che la pompa sia posizionata almeno 100 mm sotto il livello minimo del serbatoio olio. Prima di avviare la pompa effettuare spurgo aria. Verify that pump is, at least, 100 mm under the minimum level of the tank. Before starting the pump bleed the air.					

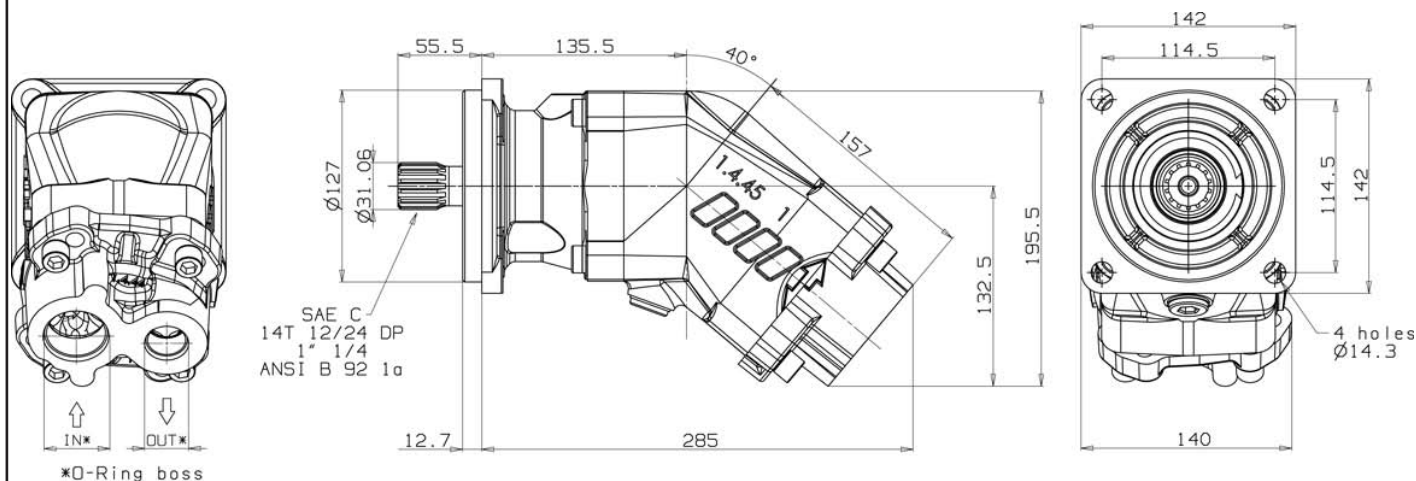

07/03/2017

99761402005 Rev. AA

Tipo pompa Pump type	Rotazione Rotation		IN	OUT
	Destra Right	Sinistra Left		
HDS SAE-C 47	61408050473	61408050479	ISO 725	ISO 725
HDS SAE-C 55	61408050553	61408050559	1 5/8-12 UN-2B SAE 20	1 1/16-12 UN-2B SAE 12
HDS SAE-C 64	61408050643	61408050649		
MDS SAE-C 80	61408050803	61408050809		
HDS SAE-C 47	61408010473	61408010479	ISO 228	ISO 228
HDS SAE-C 55	61408010553	61408010559	G 1 1/4"	G 3/4"
HDS SAE-C 64	61408010643	61408010649		
MDS SAE-C 80	61408010803	61408010809		

pag.73

O.M.F.B. S.p.A. Hydraulic Components

We reserve the right to make any changes without notice.

Edition 2016.06 No reproduction, however partial, is permitted.

Via Cave, 7/9 25050 Provaglio d'Iseo (Brescia) Italy Tel.: +39.030.9830611  
Fax: +39.030.9839207-208 Internet:www.omfb.it e-mail:contatti@omfb.it

COMPANY WITH  
QUALITY SYSTEM  
CERTIFIED BY DNV GL  
= IATF 16949 =



**CARATTERISTICHE TECNICHE DI FUNZIONAMENTO**  
TECHNICAL FEATURES

Tipo pompa Pump type	Cilindrata Displacement cm <sup>3</sup> /rev	Pressione Pressure		Velocità / Speed			Velocità min. Min. speed rpm	Peso Weight kg
		P1 bar	P3 bar	V0 rpm	V1 rpm	V2 rpm		
HDS-47	47.13	350	400	2700	1900	2500	300	14.3
HDS-55	56.70							
HDS-64	63.56	250	300	2300	1800	2100	300	14.2
MDS-80	77.25							

P1=Pressione massima continua Max. continuous pressure (100%)  
P3=Pressione massima di punta Max. peak pressure (6 sec.max)

V0=Massima continua vuoto Max. continuous speed without load  
V1=Massima continua Max. continuous speed  
V2=Massima intermittente Max. intermittent speed

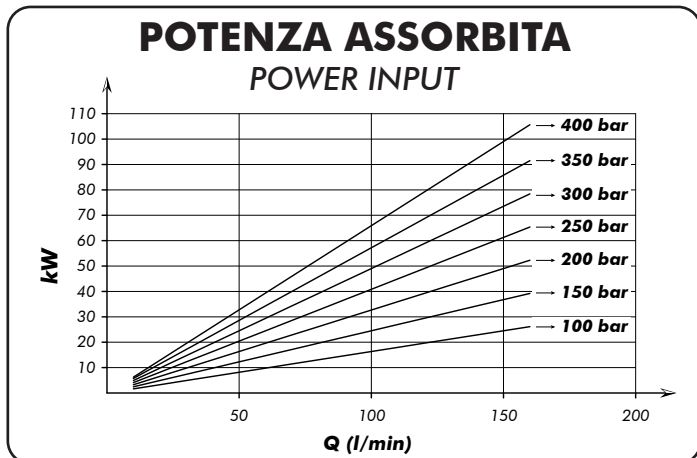
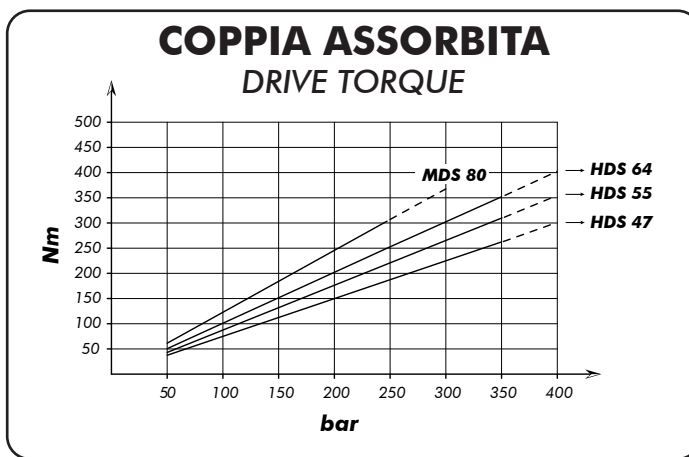
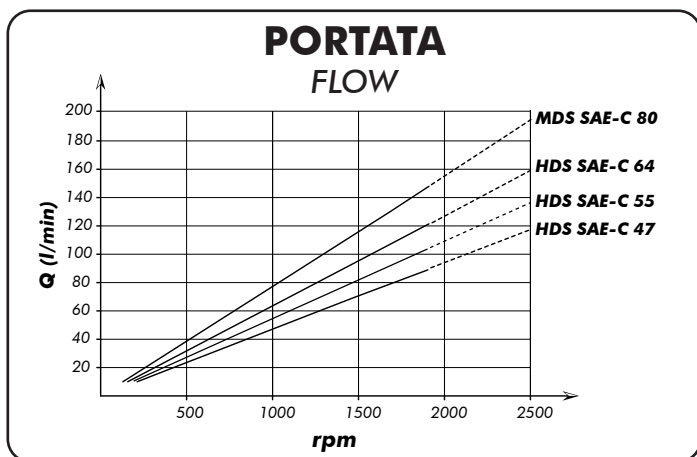

**SCELTA DEL TUBO DI ASPIRAZIONE HOW TO CHOOSE THE SUCTION PIPE SIZE**

Q Portata Flow l/min	□ interno min. tubo Min pipe diam. mm	inch	Velocità flusso Flow speed (m/s)
20	25	1"	0,68
30	32	1" 1/4	0,62
40	32		0,83
50	38	1" 1/2	0,74
60	38	1" 3/4	0,88
70	40		0,93
80	45	2"	0,84
90	45		0,94
100	50	2"	0,85
110	50		0,93
120	60	2" 3/8	0,71
130	60		0,77
140	60		0,83
150	60		0,88
160	63	2" 1/2	0,86
170	63		0,91
180	63		0,96

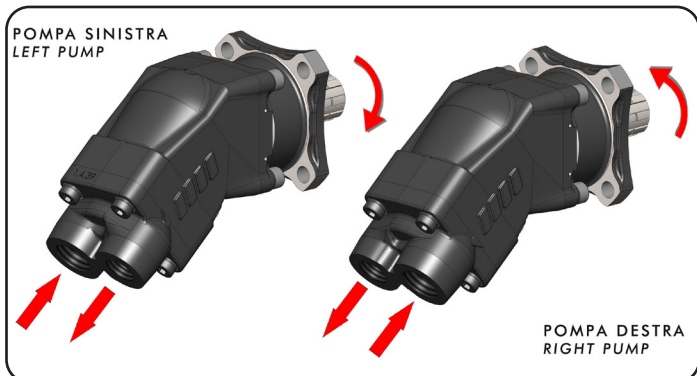

**Kit guarnizioni / Seal Kit**  
10890300223

# POMPE A PISTONI AD ASSE INCLINATO BENT AXIS PISTON PUMPS

**CODICE FAMIGLIA**  
FAMILY CODE

**614080**

**"HDS"**  
**"MDS"**

Flangia/Flange  
Albero/Shaft  
Cilin./Displ.

**SAE-C**  
**14T 12/24**  
**84-108-130**



99740060010

Fluido idraulico Fluid	Minerale o sintetico compatibile con guarnizioni: Mineral or synthetic compatible with the following seals: FKM, FPM, HNBR				
Viscosità cinematica consigliata Kinematic viscosity suggested	T media ambiente (°C) Average ambient temp. (°C)	< -40	-40 ÷ 10	10 ÷ 35	> 35
	VG (cSt = mm <sup>2</sup> /s)	16	22	32	46
Viscosità cinematica ottimale di esercizio Optimale kinematic viscosity		VG = 10 cSt ÷ 100 cSt			
Viscosità cinematica max consentita all'avviamento Max kinematic viscosity suggested at the start-up		VG = 750 cSt			
Indice di viscosità consigliato Viscosity index suggested	VI > 100	Temperatura di esercizio Working temperature -15°C ÷ 140°C			
Grado di filtrazione Oil filtering		> 200 bar: 10 µm < 200 bar: 25 µm			
Pres. di aspirazione Inlet pressure		0,85 ÷ 2 bar assoluti/absolut			
Senso di rotazione Pump rotation		Unidirezionale (Dx o Sx) Unidirectional (Right or Left)			
Verificare che la pompa sia posizionata almeno 100 mm sotto il livello minimo del serbatoio olio. Prima di avviare la pompa effettuare spurgo aria. Verify that pump is, at least, 100 mm under the minimum level of the tank. Before starting the pump bleed the air.					

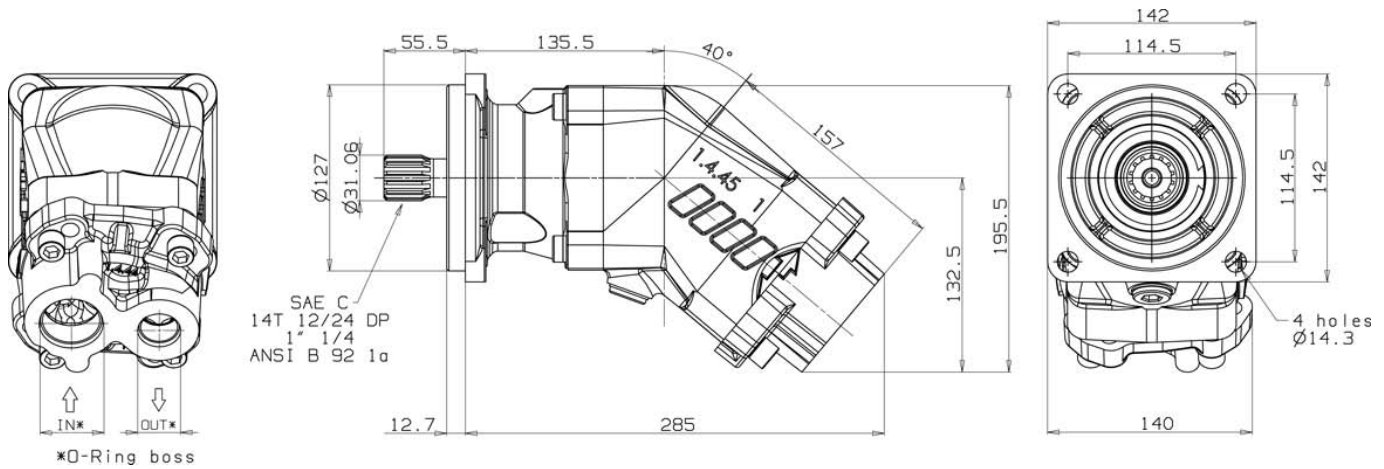

31/10/2017

Tipo pompa Pump type	Rotazione Rotation		IN	OUT
	Destra Right	Sinistra Left		
<b>HDS SAE-C 84</b>	61408050843	61408050849	1 7/8-12 UN-2B SAE 24	1 5/16-12 UN-2B SAE 16
<b>HDS SAE-C 108</b>	61408051083	61408051089		
<b>MDS SAE-C 130</b>	61408051303	61408051309		
			ISO 228	ISO 228
<b>HDS SAE-C 84</b>	61408010843	61408010849	G 1 1/4"	G 1"
<b>HDS SAE-C 108</b>	61408011083	61408011089		
<b>MDS SAE-C 130</b>	61408011303	61408011309		

99761402020 Rev. AB

pag.75



O.M.F.B. S.p.A. Hydraulic Components  
We reserve the right to make any changes without notice.  
Edition 2016.06 No reproduction, however partial, is permitted.  
Via Cave, 7/9 25050 Provaglio d'Iseo (Brescia) Italy Tel.: +39.030.9830611  
Fax: +39.030.9839207-208 Internet:www.omfb.it e-mail:contatti@omfb.it

COMPANY WITH  
QUALITY SYSTEM  
CERTIFIED BY DNV GL  
= IATF 16949 =

**CARATTERISTICHE TECNICHE DI FUNZIONAMENTO**  
**TECHNICAL FEATURES**

Tipo pompa Pump type	Cilindrata Displacement cm <sup>3</sup> /rev	Pressione Pressure		Velocità / Speed			Velocità min. Min. speed rpm	Peso Weight kg
		P1 bar	P3 bar	V0 rpm	V1 rpm	V2 rpm		
<b>HDS-84</b>	84.33	350	400	2300	1500	2000	300	21.5
<b>HDS-108</b>	107							21
<b>MDS-130</b>	131.62	250	270					21

P1=Pressione massima continua Max. continuous pressure (100%)  
P3=Pressione massima di punta Max. peak pressure (6 sec.max)

V0=Massima continua vuoto Max. continuous speed without load  
V1=Massima continua Max. continuous speed  
V2=Massima intermittente Max. intermittent speed

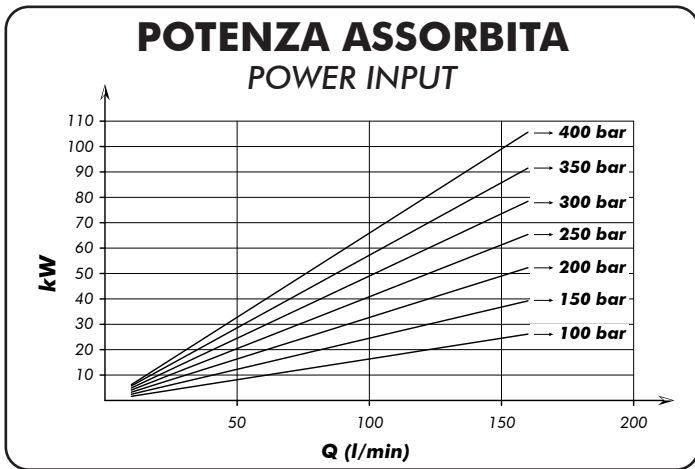
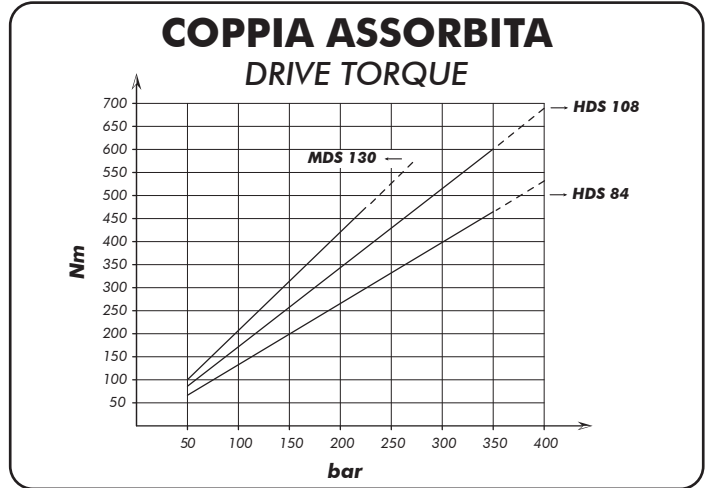
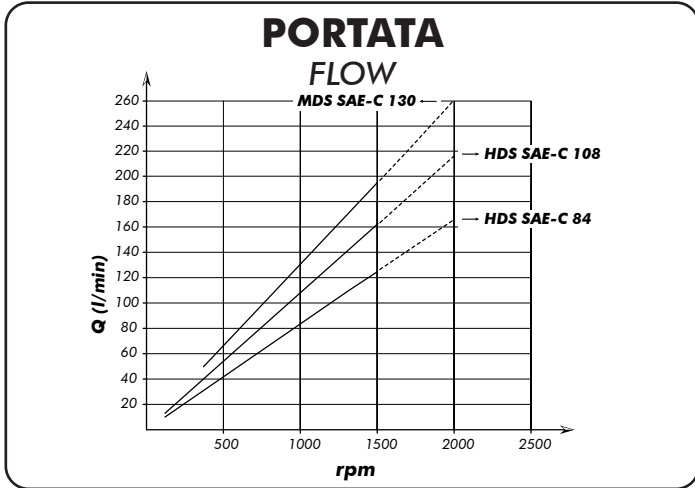

**SCELTA DEL TUBO DI ASPIRAZIONE**  
**HOW TO CHOOSE THE SUCTION PIPE SIZE**

Q Portata Flow l/min	Ø interno min. tubo Min pipe diam.		Velocità flusso Flow speed (m/s)
	mm	inch	
20	25	1"	0,68
30	32	1" 1/4	0,62
40	32	1" 1/4	0,83
50	38	1" 1/2	0,74
60	38	1" 1/2	0,88
70	40	1" 9/16	0,93
80	45	1" 3/4	0,84
90	45	1" 3/4	0,94
100	50	2"	0,85
110	50	2"	0,93
120	60	2" 3/8	0,71
130	60		0,77
140	60		0,83
150	60	2" 1/2	0,88
160	63		0,86
170	63		0,91
180	63	2" 1/2	0,96

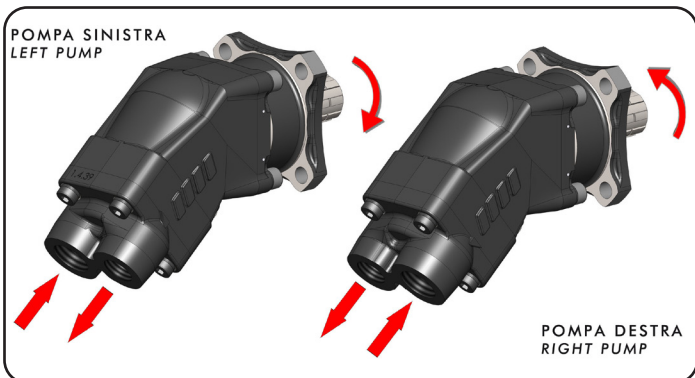

Per garantire corrette condizioni di aspirazione la velocità del flusso non deve superare 1 m/sec.  
To ensure the proper suction pipe size the flow speed should not exceed 1mt/sec.

**Kit guarnizioni / Seal Kit**  
10890300232