

Data Sheet

# Electro-hydraulic actuator type PVHC

The PVHC is an electrical actuator module for main spool control in PVG 32 and PVG 100. The actuator uses two current controlled proportional pressure-reducing valves. PVHC does not use the known PVE internal closed loop control technology, and therefore does not offer any kind of fault monitoring system, neither active nor passive.

## Function

With electrical proportional actuation, the main spool position is adjusted so that its position corresponds to an electrical control signal.

The control signal is converted into a hydraulic pressure signal that moves the main spool in the PVG.

This is done by means of two proportional pressure-reducing valves. The electrical actuator can be controlled either by a current amplifier card, or directly from a programmable micro-controller.

(see drawing fig. 1 page 2).

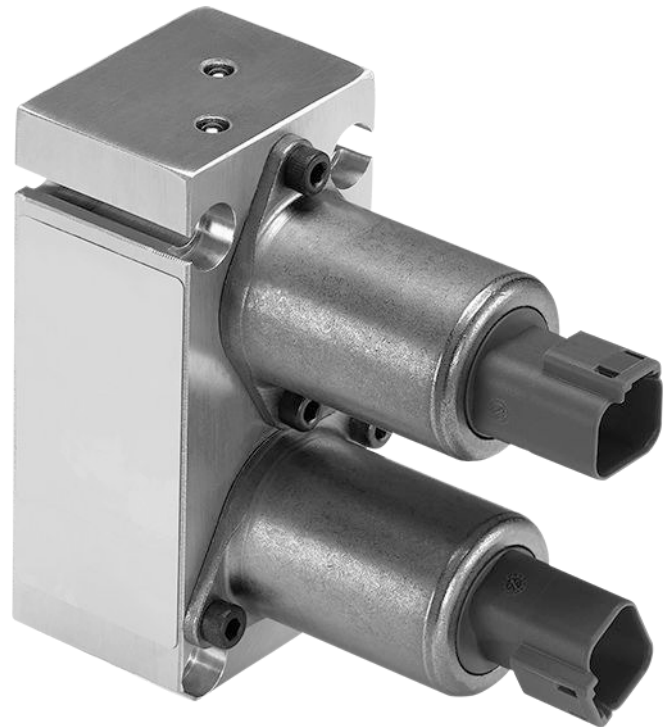

## Features

- PVM current control signals
- AMP JPT and DEUTSCH DT connector options
- 12 V or 24 V supply options
- Only to be used with 25 bar pilot pressure and hydraulic spring
- Only standard mounting on PVG 32 and PVG 100.

---

Comprehensive technical literature is  
online at [powersolutions.danfoss.com](http://powersolutions.danfoss.com)

---

Fig 1.

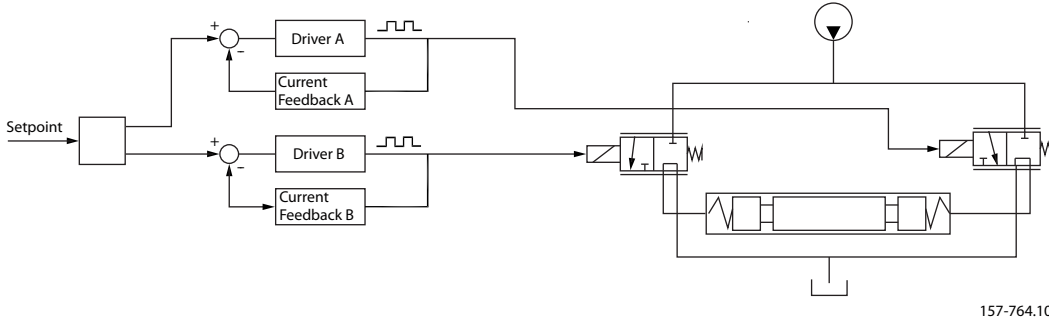

**Hydraulic Actuation**

It is necessary only to use the PVHC in combination with 25 bar [362.6 psi] pilot pressure, 157B5190 (OC) and -5191 (CC), and standard FC spools fitted for hydraulic actuation. See PVG 32 Technical Information DKMH.PK.570.C4.02. Because of the 25 bar pilot pressure, it is not possible to combine PVHC with PVE on a PVG32 or PVG 100.

**Warning**

All marks and all types of directional control valves – including proportional valves – can fail and cause serious damage. It is therefore important to analyze all aspects of the application. Because the proportional valves are used in many different operation conditions and applications, the manufacturer of the application is alone responsible for making the final selection of the products – and assuring that all performance, safety and warning requirements of the application are met. The process of choosing the control system – and safety level – could e.g. be governed by EN 954-1 (Safety related parts of control system).

**Technical data: Input-Output relation**

*Temperature*

|         | Temperature range               |
|---------|---------------------------------|
| Ambient | -30°C to 80°C [-22 °F to 176°F] |
| Medium  | -20°C to 80°C [-4 °F to 176°F]  |

*Input control*

| Parameter              | Control range: 12 V; 24 V       |
|------------------------|---------------------------------|
| Current                | 0 - 1500 mA; 0 - 750 mA         |
| Pressure control range | 5 to 15 bar [72.5 to 217.5 psi] |

*Enclosure*

| Connector type  | Protection class |
|-----------------|------------------|
| DEUTSCH DT      | IP 65            |
| AMP JPT 12/24 V | IP 65            |

*Filtering*

|                                   |   |
|-----------------------------------|---|
| Filtering in the hydraulic system | Max. permissible degree of contamination (ISO 4406, 1999 version): 23/19/16 |
|-----------------------------------|---|

Fig 2.

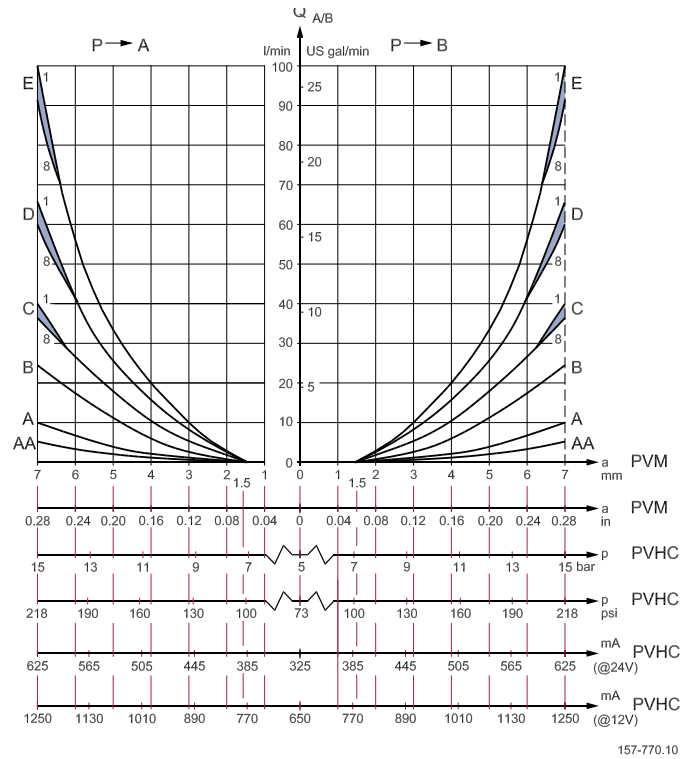

Danfoss can accept no responsibility for possible errors in catalogues, brochures and other printed material. Danfoss reserves the right to alter its products without notice. This also applies to products already on order provided that such alterations can be made without changes being necessary in specifications already agreed. All trademarks in this material are property of the respective companies. Danfoss and the Danfoss logotype are trademarks of Danfoss A/S. All rights reserved.