

# HYDRAULIC MOTORS RL

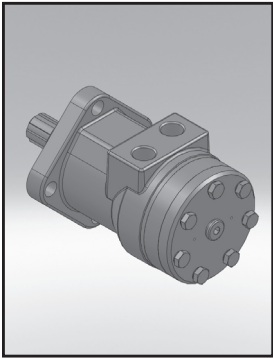

## APPLICATION

- » Conveyors
- » Feeding mechanism of robots and manipulators
- » Metal working machines
- » Textile machines
- » Agricultural machines
- » Food industries
- » Mining machinery etc.

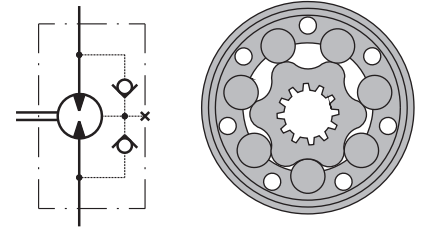

## CONTENTS

Specification data .....	72
Dimensions and mounting ....	73
Shaft extensions .....	74
Permissible shaft loads .....	75
Order code .....	75

## OPTIONS

- » Model - Spool valve, gerotor
- » Antifriction needle bearing
- » Flange mount
- » Shafts - straight, splined and tapered
- » Metric and BSPP ports
- » Other special features

## GENERAL

<b>Max. Displacement,</b> cm <sup>3</sup> /rev [in <sup>3</sup> /rev]	397 [24.4]
<b>Max. Speed,</b> [RPM]	970
<b>Max. Torque,</b> daNm [lb-in]	cont.: 61 [5400] int.: 69 [6100]
<b>Max. Output,</b> kW [HP]	16 [21.5]
<b>Max. Pressure Drop,</b> bar [PSI]	cont.: 175 [2540] int.: 200 [2900]
<b>Max. Oil Flow,</b> lpm [GPM]	75 [19.8]
<b>Min. Speed,</b> [RPM]	10
<b>Permissible Shaft Loads,</b> daN [lbs]	P <sub>a</sub> =500 [1124]
<b>Pressure fluid</b>	Mineral based- HLP(DIN 51524) or HM(ISO 6743/4)
<b>Temperature range,</b> °C [°F]	-40÷140 [-40÷284]
<b>Optimal Viscosity range,</b> mm <sup>2</sup> /s [SUS]	20÷75 [98÷347]
<b>Filtration</b>	ISO code: 18/16/13 According to ISO 4406-1999

### Oil flow in drain line

Pressure drop bar [PSI]	Viscosity mm <sup>2</sup> /s [SUS]	Oil flow in drain line lpm [GPM]
100 [1450]	20 [98]	2,5 [.660]
	35 [164]	1,8 [.476]
140 [2030]	20 [98]	3,5 [.925]
	35 [164]	2,8 [.740]

### Pressure Losses

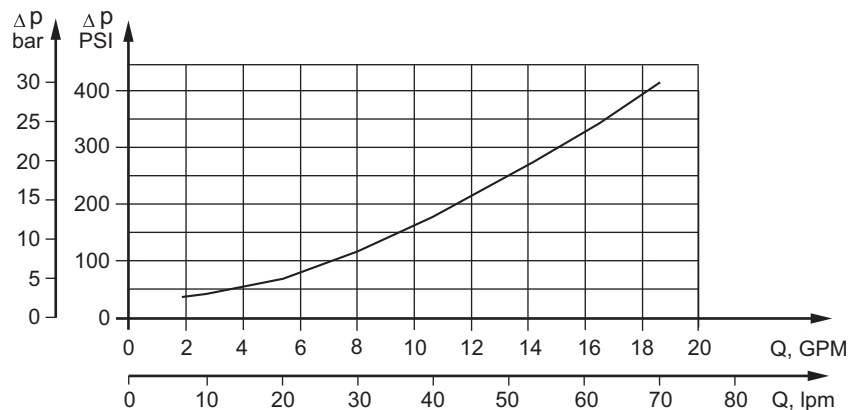

## SPECIFICATION DATA

Type	RL 50	RL 80	RL 100	RL 125	RL 160	RL 200	RL 250	RL 315	RL 400	
<b>Displacement, cm<sup>3</sup>/rev [in<sup>3</sup>/rev]</b>	51,5 [3.14]	80,3 [4.90]	99,8 [6.09]	125,7 [7.67]	159,6 [9.74]	199,8[12.19]	250,1[15.26]	315,7[19.26]	397 [24.4]	
<b>Max. Speed, [RPM]</b>	Cont.	775	750	600	475	375	300	240	190	
	Int.*	970	940	750	600	470	375	300	240	
<b>Max. Torque, daNm [lb-in]</b>	Cont.	10 [885]	19,5 [1725]	24 [2125]	30 [2655]	38 [3360]	45 [4000]	54 [4780]	55 [4870]	61 [5400]
	Int.*	13 [1150]	22 [1947]	28 [2480]	34 [3010]	43 [3805]	50 [4425]	61 [5400]	69 [6100]	69 [6100]
	Peak**	17 [1505]	27 [2390]	32 [2832]	37 [3275]	46 [4070]	56 [4960]	71 [6280]	84 [77430]	87 [7700]
<b>Max. Output, kW [HP]</b>	Cont.	7 [9.5]	12,5 [17]	13 [17.4]	12,5 [16.8]	12,5 [16.8]	11 [14.8]	10 [13.4]	9 [12]	7,5 [10]
	Int.*	8,5 [11.9]	15 [20.1]	15 [20.1]	14,5 [19]	14 [18.8]	13 [17.4]	12 [16.1]	10 [13.4]	9 [12]
<b>Max. Pressure Drop, bar [PSI]</b>	Cont.	140 [2030]	175 [2540]	175 [2540]	175 [2540]	175 [2540]	175 [2540]	175 [2540]	135 [1960]	110 [1600]
	Int.*	175 [2540]	200 [2900]	200 [2900]	200 [2900]	200 [2900]	200 [2900]	200 [2900]	175 [2540]	140 [2030]
	Peak**	225 [3260]	225 [3260]	225 [3260]	225 [3260]	225 [3260]	225 [3260]	225 [3260]	210 [3045]	175 [2540]
<b>Max. Oil Flow, lpm [GPM]</b>	Cont.	40 [11]	60 [16]	60 [16]	60 [16]	60 [16]	60 [16]	60 [16]	60 [16]	60 [16]
	Int.*	50 [13]	75 [20]	75 [20]	75 [20]	75 [20]	75 [20]	75 [20]	75 [20]	75 [20]
<b>Max. Inlet Pressure, bar [PSI]</b>	Cont.	175 [2540]	175 [2540]	175 [2540]	175 [2540]	175 [2540]	175 [2540]	175 [2540]	175 [2540]	175 [2540]
	Int.*	200 [2900]	200 [2900]	200 [2900]	200 [2900]	200 [2900]	200 [2900]	200 [2900]	200 [2900]	200 [2900]
	Peak**	225 [3260]	225 [3260]	225 [3260]	225 [3260]	225 [3260]	225 [3260]	225 [3260]	225 [3260]	225 [3260]
<b>Max. Return Pressure without Drain Line or Max. Pressure in Drain Line, bar [PSI]</b>	Cont. 0-100 RPM	100 [1450]	100 [1450]	100 [1450]	100 [1450]	100 [1450]	100 [1450]	100 [1450]	100 [1450]	100 [1450]
	Cont. 100-300 RPM	50 [725]	50 [725]	50 [725]	50 [725]	50 [725]	50 [725]	50 [725]	50 [725]	50 [725]
	Cont. 300-600 RPM	25 [365]	25 [365]	25 [365]	25 [365]	25 [365]	25 [365]	25 [365]	25 [365]	25 [365]
	Cont. >600 RPM	15 [220]	15 [220]	15 [220]	15 [220]	15 [220]	15 [220]	15 [220]	15 [220]	15 [220]
	Int.* 0-max RPM	100 [1450]	100 [1450]	100 [1450]	100 [1450]	100 [1450]	100 [1450]	100 [1450]	100 [1450]	100 [1450]
<b>Max. Return Pressure with Drain Line, bar [PSI]</b>	Cont.	140 [2030]	175 [2540]	175 [2540]	175 [2540]	175 [2540]	175 [2540]	175 [2540]	175 [2540]	175 [2540]
	Int.*	175 [2540]	200 [2900]	200 [2900]	200 [2900]	200 [2900]	200 [2900]	200 [2900]	200 [2900]	200 [2900]
	Peak**	225 [3260]	225 [3260]	225 [3260]	225 [3260]	225 [3260]	225 [3260]	225 [3260]	225 [3260]	225 [3260]
<b>Max. Starting Pressure with Unloaded Shaft, bar [PSI]</b>	10 [145]	10 [145]	10 [145]	9 [130]	7 [102]	5 [73]	5 [73]	5 [73]	5 [73]	
<b>Min. Starting Torque, daNm [lb-in]</b>	8 [710]	15 [1330]	20 [1770]	25 [2215]	32 [2835]	37 [3275]	45 [3983]	45 [3983]	49 [4335]	
<b>Min. Speed***, [RPM]</b>	10	10	10	10	10	10	10	10	10	
<b>Weight, kg [lb]</b>	7,7 [17]	7,8 [17.2]	8,1 [17.8]	8,2 [18]	8,4 [18.5]	8,9 [19.6]	9,3 [20.5]	10,0 [22]	10,7 [23.6]	

\* Intermittent operation: the permissible values may occur for max. 10% of every minute.

\*\* Peak load: the permissible values may occur for max. 1% of every minute.

\*\*\* For speeds lower than given, consult factory or your regional manager.

- Intermittent speed and intermittent pressure must not occur simultaneously.
- Recommended filtration is per ISO cleanliness code 20/16. A nominal filtration of 25 micron or better.
- Recommend using a premium quality, anti-wear type mineral based hydraulic oil HLP(DIN51524) or HM ( ISO 6743/4).  
If using synthetic fluids consult the factory for alternative seal materials.
- Recommended minimum oil viscosity 13 mm<sup>2</sup>/s [70 SUS] at 50°C [122°F].
- Recommended maximum system operating temperature is 82°C [180°F].
- To assure optimum motor life fill with fluid prior to loading and run at moderate load and speed for 10-15 minutes.

**DIMENSIONS and MOUNTING DATA**

Shaft Dim.  
See Page 74

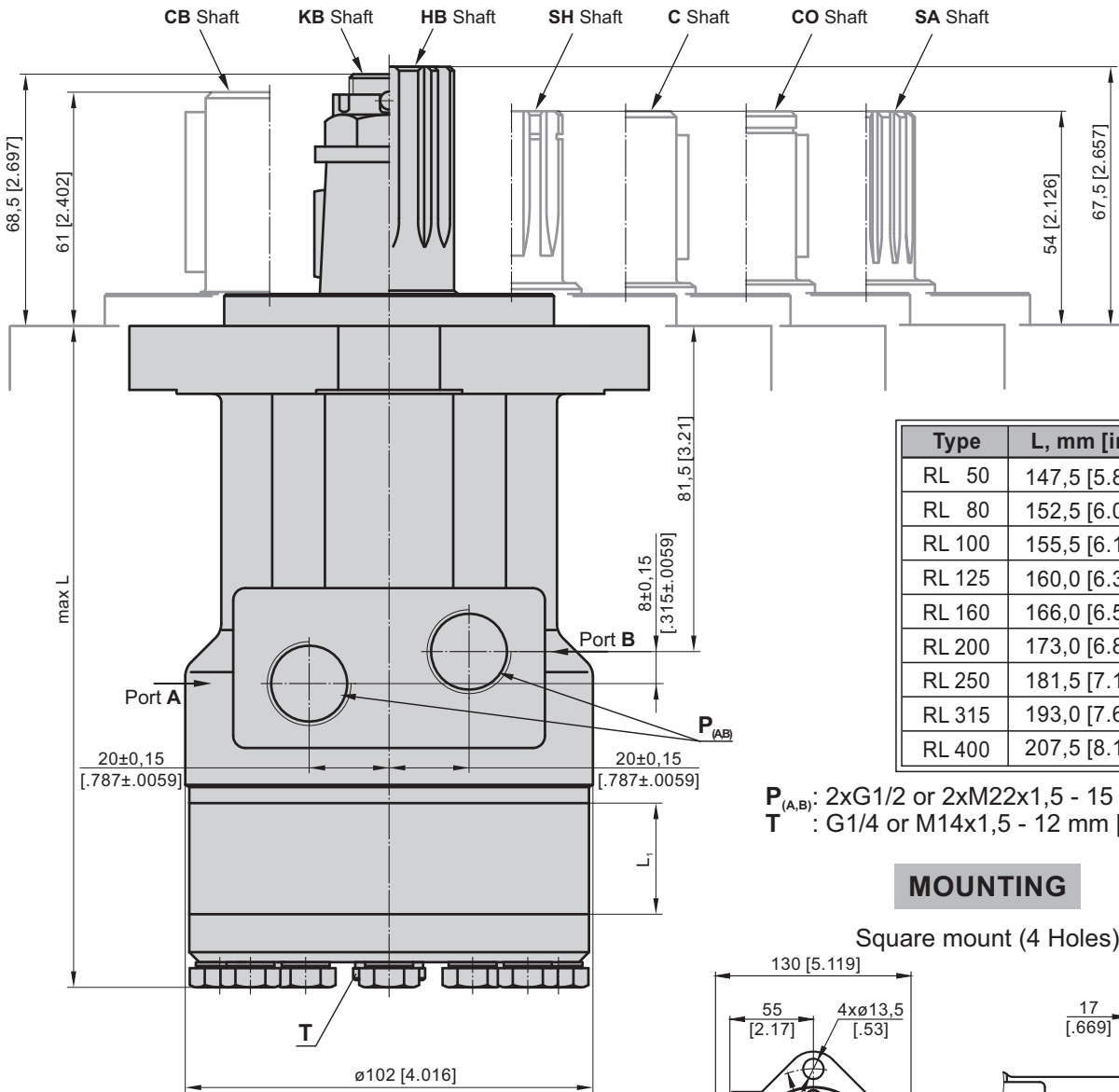

Type	L, mm [in]	L <sub>1</sub> , mm [in]
RL 50	147,5 [5.80]	9,0 [ .35]
RL 80	152,5 [6.00]	14,0 [ .55]
RL 100	155,5 [6.12]	17,4 [ .69]
RL 125	160,0 [6.30]	21,8 [ .86]
RL 160	166,0 [6.54]	27,8 [1.09]
RL 200	173,0 [6.81]	34,8 [1.37]
RL 250	181,5 [7.15]	43,5 [1.71]
RL 315	193,0 [7.60]	54,8 [2.16]
RL 400	207,5 [8.17]	69,4 [2.73]

P<sub>(A,B)</sub>: 2xG1/2 or 2xM22x1,5 - 15 mm [.59 in] depth  
T : G1/4 or M14x1,5 - 12 mm [.47 in] depth

**MOUNTING**

Square mount (4 Holes)

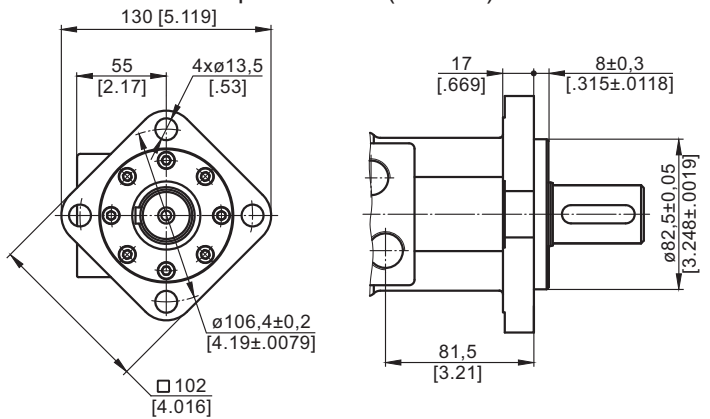

**Standard Rotation**  
Viewed from Shaft End  
Port A Pressurized - CW  
Port B Pressurized - CCW



**Reverse Rotation**  
Viewed from Shaft End  
Port A Pressurized - CCW  
Port B Pressurized - CW

**F** Oval mount (4 Holes)

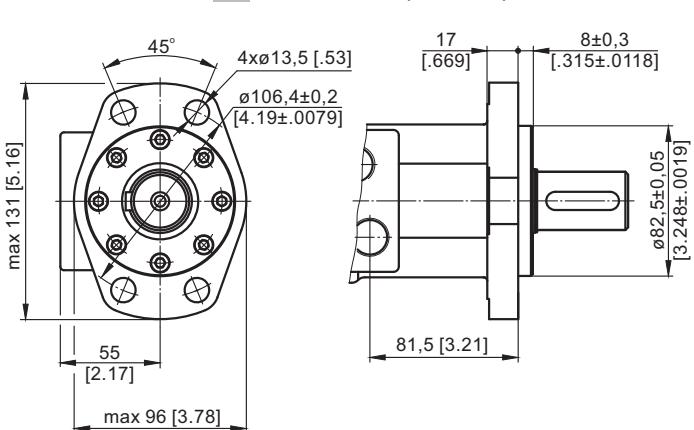

**A** Oval mount (2 Holes)

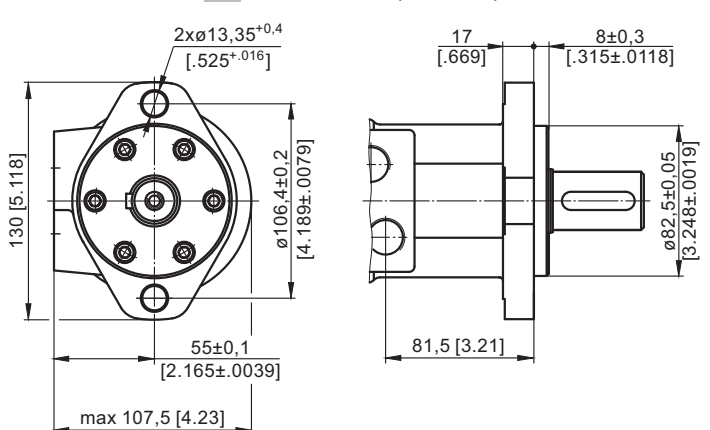

**SHAFT EXTENSIONS**

**C** -  $\varnothing 25$  straight, Parallel key A8x7x30 DIN 6885  
Max. Torque 34 daNm [3010 lb-in]

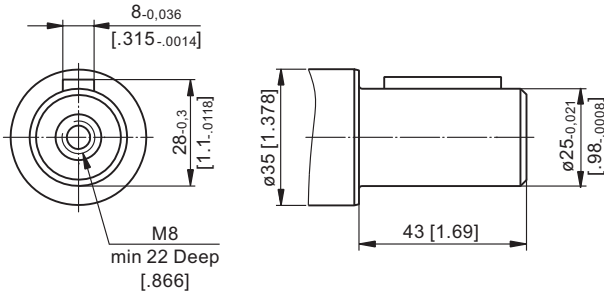

**SA** - splined B25x22 DIN 5482  
Max. Torque 40 daNm [3540 lb-in]

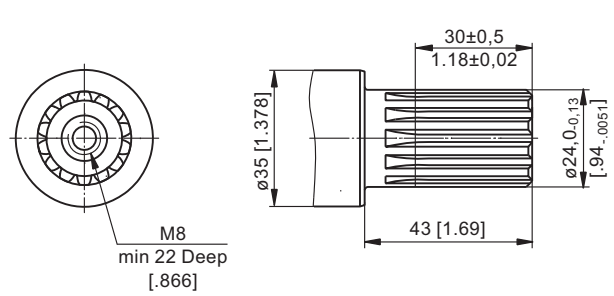

**CO** -  $\varnothing 1$ " straight, Parallel key  $\frac{1}{4}$ "x $\frac{1}{4}$ "x $\frac{1}{4}$ " BS46  
Max. Torque 34 daNm [3010 lb-in]

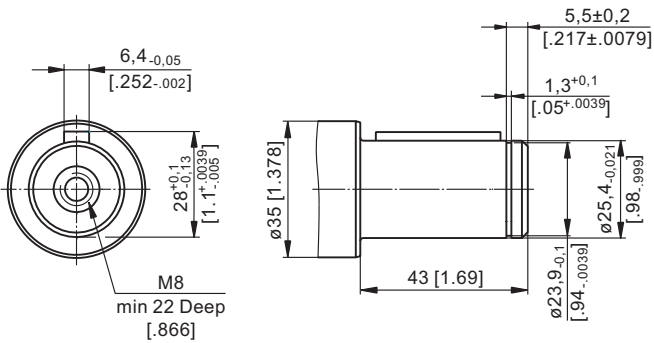

**CB** -  $\varnothing 32$  straight, Parallel key A10x8x40 DIN 6885  
Max. Torque 77 daNm [6815 lb-in]

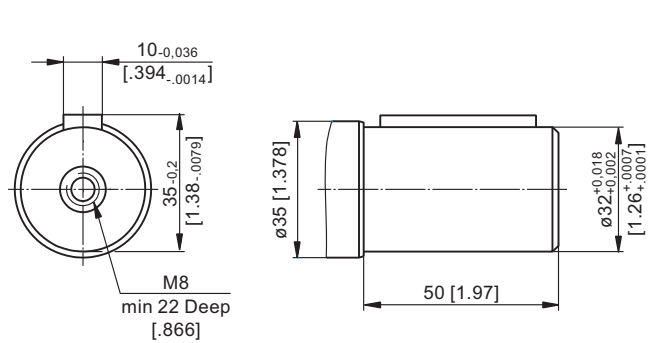

**SH** - splined, BS 2059 (SAE 6B)  
Max. Torque 40 daNm [3540 lb-in]

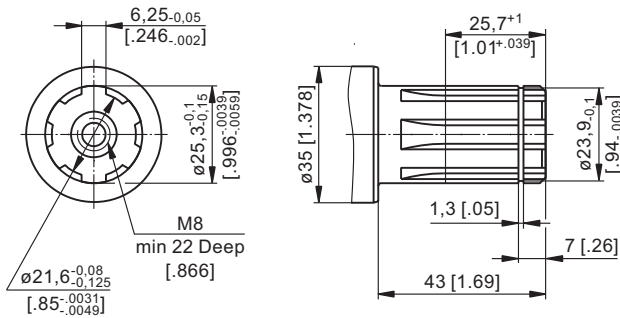

**HB** -  $\varnothing 1\frac{1}{4}$ " splined 14T, DP12/24 ANSI B92.1-1976  
Max. Torque 95 daNm [8410 lb-in]

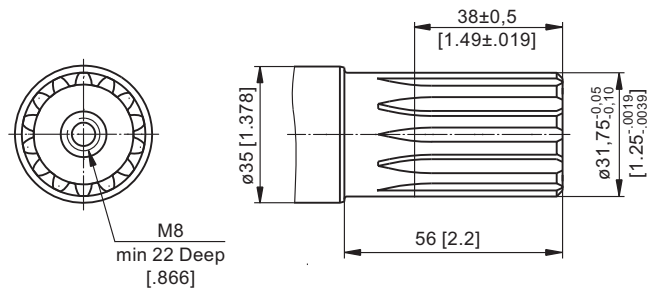

**KB** - tapered 1:10, Woodruff key 6x9 DIN6888  
Max. Torque 95 daNm [8410 lb-in]

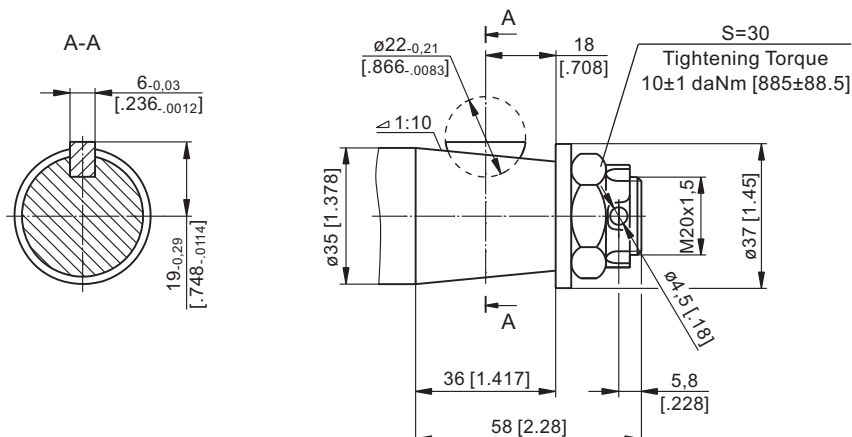

**PERMISSIBLE SHAFT LOADS for PL and RL MOTORS**

The curves apply to a B10 bearings life of 2000 hrs

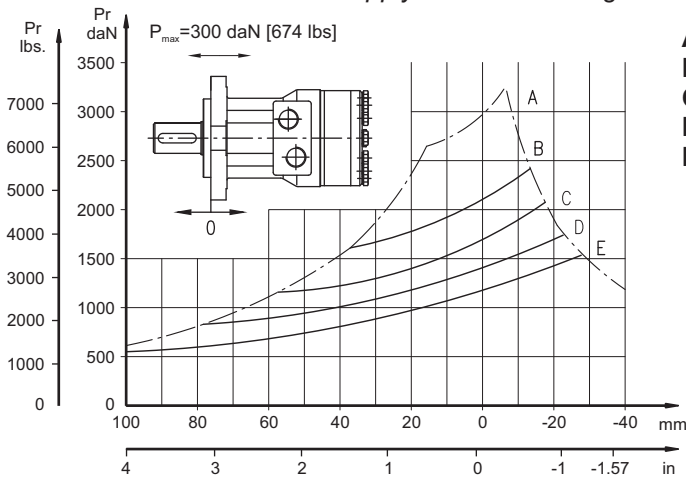

**MAX. PERMISSIBLE SHAFT SEAL PRESSURE**

Max return pressure without drain line or max. pressure in drain line

— - continuous operations  
- - - - intermittent operations

1: Drawing for Standard Shaft Seal  
2: Drawing for High Pressure Seal ("U" Seal)

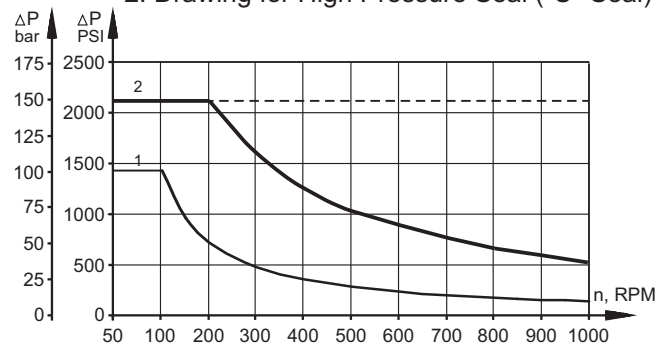

**ORDER CODE**

1	2	3	4	5	6	7
<b>RL</b>						

**Pos.1 - Mounting Flange**

omit - Square mount, four holes

**F** - Oval mount, four holes

**A** - Oval mount, two holes

**Pos.2 - Displacement code\***

**50** - 51,5 cm<sup>3</sup>/rev [3.14 in<sup>3</sup>/rev]

**80** - 80,3 cm<sup>3</sup>/rev [4.90 in<sup>3</sup>/rev]

**100** - 99,8 cm<sup>3</sup>/rev [6.09 in<sup>3</sup>/rev]

**125** - 125,7 cm<sup>3</sup>/rev [7.67 in<sup>3</sup>/rev]

**160** - 159,6 cm<sup>3</sup>/rev [9.74 in<sup>3</sup>/rev]

**200** - 199,8 cm<sup>3</sup>/rev [12.19 in<sup>3</sup>/rev]

**250** - 250,1 cm<sup>3</sup>/rev [15.26 in<sup>3</sup>/rev]

**315** - 315,7 cm<sup>3</sup>/rev [19.26 in<sup>3</sup>/rev]

**400** - 397,0 cm<sup>3</sup>/rev [24.40 in<sup>3</sup>/rev]

**Pos.3 - Shaft Extensions\*\***

**C** -  $\varnothing 25$  straight, Parallel key A8x7x30 DIN6885

**CO** -  $\varnothing 1$ " straight, Parallel key  $1/4$ "x $1/4$ "x $1 1/4$ " BS46

**SH** -  $\varnothing 25,3$  splined, BS 2059 (SAE 6B)

**SA** -  $\varnothing 24$  splined, B25x22 DIN 5482

**CB** -  $\varnothing 32$  straight, Parallel key A10x8x40 DIN6885

**HB** -  $\varnothing 1 1/4$ " splined 14T ANSI B92.1-1976

**KB** -  $\varnothing 35$  tapered 1:10, Woodruff key 6x9 DIN6888

**Pos.4 - Shaft Seal Version**

omit - Standard shaft seal

**U** - High pressure shaft seal

**Pos.5 - Ports**

omit - BSPP (ISO 228)

**M** - Metric (ISO 262)

**Pos.6 - Special Features (see page 125)**

**Pos.7 - Design Series**

omit - Factory specified

**NOTES:** \* For the Function Diagrams data please look at "M+S Hydraulic" Catalogue for MR motors, pages 35+39.

\*\* The permissible output torque for shafts must not be exceeded.

The hydraulic motors are mangano-phosphatized as standard.