

## Hydraulic Power Pack with Under Oil Motor

### SPA 01

$Q_{max}$  10 l/min •  $p_{max}$  250 bar •  $P_{max}$  3 kW

#### Example: plastic tank version

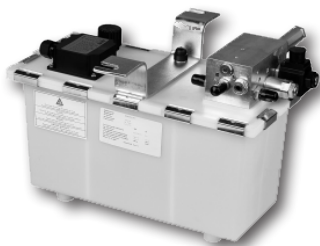

#### Example: steel tank version additional valves in stacking assembly

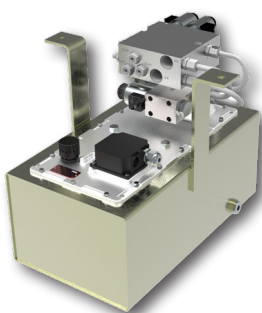

#### Technical Features

- › AC electro-hydraulic compact unit with under oil motor
- › Compact design with reduced overall dimensions for production cost saving
- › Main applications are lifting platforms
- › 3 central block basic circuits option
- › Possibility of building up an additional circuit in the form of vertical or horizontal stacking assembly
- › One- and three-phase motors with power ratings of up to 3 kW
- › Tank capacities from 7 to 30 l with optional plastic tanks for cost saving
- › In the standard version, the aluminium basic block is without surface protection and steel plate are zinc coated for 240 h protection acc. to ISO 9227

#### Functional Description

The under oil power packs are designed for applications which require low noise levels as well as small envelope dimensions. They are designed to operated only occasionally, thus being suitable mainly for the use in lifting platforms, elevating tables and handling devices. Each power pack consists of an electric motor, a pump, a manifold and a tank. The aluminum body forms the base of the power pack, on which all the main components, including the hydraulic elements, are mounted. The function of the power packs is apparent from the respective hydraulic circuit diagrams. The desired combination of particular components and hydraulic elements can be defined by reference to the ordering code and the respective tables. The additional hydraulic circuits can be built up valve sizes 03 (RPEK), 04 (CETOP 02) and 06 (CETOP 03). The size 03 (RPEK) is in the form of a sectional directional valve.

The mounting position of the power pack is horizontal - see Power Pack Dimensions. The basic combinations of electric motors and pumps, as well as their code designations, are shown in table 1.

#### Technical Data

|                                    |                    |                                   |
|------------------------------------|--------------------|-----------------------------------|
| Flow rate                          | l/min              | see table 1                       |
| Working pressure                   | bar                | see table 1                       |
| Max. operating pressure            | bar                | see table 1                       |
| Tank capacity                      | l                  | 7, 10, 20, 30                     |
| Type of hydraulic pump             |                    | Gear pump, CLOCKWISE              |
| Electrical Motor power ratings     | kW                 | 0.55 - 3                          |
| Type of electric motor             |                    | one- and three-phase              |
| Voltage of electric motor          | V                  | 230   400                         |
| Duty cycle S3 of electric motor    | %                  | 20                                |
| Frequency                          | Hz                 | 50                                |
| Protection degree of power unit    |                    | IP 55                             |
| Viscosity range                    | mm <sup>2</sup> /s | 20 ... 100                        |
| Fluid temperature range            | °C                 | -20 ... +80                       |
| Ambient temperature max.           | °C                 | +50                               |
| Thread of functional ports P, T, M |                    | G1/4                              |
|                                    | Data Sheet         | Type                              |
| General information                | GI_0060            | Products and operating conditions |

#### Ordering Code

SPA 01 - [ ] / [ ] . [ ] - [ ] - [ ] - [ ] / [ ]

#### Under oil power pack

#### Pump displacement in cm<sup>3</sup>

|     |    |     |    |
|-----|----|-----|----|
| 0.8 | 08 | 3.6 | 36 |
| 1.2 | 12 | 4.4 | 44 |
| 1.6 | 16 | 4.8 | 48 |
| 2.1 | 21 | 5.8 | 58 |
| 2.5 | 25 | 6.2 | 62 |
| 3.3 | 33 | 7.9 | 79 |

#### Code of the electric motor - see table 1

#### Start-up module

without start-up module  
with start-up module

0  
M

#### Type of the block - see page 3

#### Code of the tank

|      |    |
|------|----|
| 7 l  | 7  |
| 10 l | 10 |
| 20 l | 20 |
| 30 l | 30 |

#### Solenoid voltage

|       |         |       |                    |
|-------|---------|-------|--------------------|
| 01200 | 12 V DC | 06000 | 60 V DC            |
| 01400 | 14 V DC | 10200 | 102 V DC           |
| 02100 | 21 V DC | 20500 | 205 V DC           |
| 02400 | 24 V DC | 02450 | 24 V / 50 (60) HZ  |
| 04200 | 42 V DC | 11550 | 115 V / 50 (60) HZ |
| 04800 | 48 V DC | 23050 | 230 V / 50 (60) HZ |

#### Nominal size of stacking assembly elements

without stacking assembly  
size 03  
size 04  
size 06

0  
3  
4  
6

#### Number of add-on units

without stacking assembly  
1 section  
2 sections  
3 sections  
4 sections  
5 sections

0  
1  
2  
3  
4  
5

**Tab. 1a**

| Code of the electric motor |       |      | Code of the pump        |          |          |          |          |          |
|----------------------------|-------|------|-------------------------|----------|----------|----------|----------|----------|
|                            |       |      | 08 GP1..                | 12 GP1.. | 16 GP1.. | 21 GP1.. | 25 GP1.. | 33 GP1.. |
| $p_{max}^{**}$ [bar]       |       |      | 250                     |          |          |          |          |          |
| rpm [1/min]                | 400 V | kW   | $Q/p_n^*$ [l/min]/[bar] |          |          |          |          |          |
| 1500                       | 13    | 0.55 |                         | 1.5/175  | 2.0/130  | 2.6/100  | 3.1/85   | 4.2/65   |
|                            | 14    | 0.75 |                         |          | 1.9/190  | 2.5/145  | 3.0/120  | 3.9/90   |
|                            | 15    | 1.10 |                         |          | 2.1/200  | 2.8/190  | 3.3/160  | 4.4/120  |
|                            | 16    | 1.50 |                         |          |          |          | 3.2/200  | 4.2/170  |
|                            | 17    | 2.20 |                         |          |          |          |          |          |
|                            | 18    | 3.0  |                         |          |          |          |          |          |
| 3000***                    | 30    | 0.55 | 2.2/120                 | 3.2/80   | 4.3/60   | 5.6/45   | 6.7/40   | 8.9/30   |
|                            | 31    | 0.75 | 2.2/160                 | 3.2/110  | 4.3/80   | 5.6/65   | 6.7/55   | 8.9/40   |
|                            | 32    | 1.10 | 2.2/200                 | 3.2/165  | 4.3/120  | 5.6/95   | 6.7/80   | 8.9/60   |
|                            | 33    | 1.50 |                         | 3.2/200  | 4.3/165  | 5.6/130  | 6.7/110  | 8.9/80   |
|                            | 34    | 2.20 |                         |          | 4.2/200  | 5.5/190  | 6.6/160  | 8.7/120  |
|                            | 35    | 3.00 |                         |          |          |          | 6.4/200  | 8.5/170  |
| rpm [1/min]                | 230 V | kW   | $Q/p_n^*$ [l/min]/[bar] |          |          |          |          |          |
| 1500                       | 5     | 0.55 |                         | 1.6/165  | 2.1/125  | 2.7/100  | 3.2/80   | 4.3/60   |
|                            | 6     | 0.75 |                         | 1.6/200  | 2.1/170  | 2.8/130  | 3.3/110  | 4.4/80   |
|                            | 7     | 1.10 |                         |          |          | 2.8/190  | 3.3/160  | 4.4/120  |
|                            | 8     | 1.50 |                         |          |          |          | 3.3/200  | 4.4/165  |

**Tab. 1b**

| Code of the electric motor |       |      | Code of the pump        |          |          |          |          |          |
|----------------------------|-------|------|-------------------------|----------|----------|----------|----------|----------|
|                            |       |      | 36 GP1..                | 44 GP1.. | 48 GP1.. | 58 GP1.. | 62 GP1.. | 79 GP1.. |
| $p_{max}^{**}$ [bar]       |       |      | 250                     |          |          | 200      |          |          |
| rpm [1/min]                | 400 V | kW   | $Q/p_n^*$ [l/min]/[bar] |          |          |          |          |          |
| 1500                       | 13    | 0.55 | 4.5/60                  | 5.5/50   | 6.0/45   | 7.3/35   | 7.8/35   | 9.9/25   |
|                            | 14    | 0.75 | 4.3/85                  | 5.2/70   | 5.7/65   | 6.9/50   | 7.4/50   | 9.4/40   |
|                            | 15    | 1.10 | 4.8/110                 | 5.8/90   | 6.3/85   | 7.7/70   | 8.2/65   | 10.4/50  |
|                            | 16    | 1.50 | 4.6/155                 | 5.6/130  | 6.2/115  | 7.4/100  | 8.0/90   | 10.1/70  |
|                            | 17    | 2.20 |                         | 5.0/200  | 5.5/190  | 6.6/160  | 7.1/150  | 9.0/120  |
|                            | 18    | 3.00 |                         |          | 5.9/200  | 7.1/200  | 7.6/180  | 9.7/150  |
| 3000***                    | 30    | 0.55 |                         |          |          |          |          |          |
|                            | 31    | 0.75 | 9.7/35                  |          |          |          |          |          |
|                            | 32    | 1.10 | 9.7/55                  | 11.8/45  | 12.9/40  | 15.6/35  |          |          |
|                            | 33    | 1.50 | 9.7/75                  | 11.8/60  | 12.9/55  | 15.6/45  | 16.7/40  |          |
|                            | 34    | 2.20 | 9.5/110                 | 11.6/90  | 12.7/85  | 15.3/70  | 16.4/65  | 20.9/50  |
|                            | 35    | 3.00 | 9.3/155                 | 11.3/125 | 12.4/115 | 15.0/95  | 16.0/90  | 20.4/70  |
| rpm [1/min]                | 230 V | kW   | $Q/p_n^*$ [l/min]/[bar] |          |          |          |          |          |
| 1500                       | 5     | 0.55 | 4.7/55                  | 5.7/45   | 6.2/40   | 7.5/35   | 8.0/30   | 10.2/25  |
|                            | 6     | 0.75 | 4.8/75                  | 5.9/60   | 6.4/55   | 7.7/45   | 8.3/45   | 10.5/35  |
|                            | 7     | 1.10 | 4.8/110                 | 5.9/90   | 6.4/80   | 7.7/70   | 8.5/65   | 10.5/50  |
|                            | 8     | 1.50 | 4.8/150                 | 5.9/120  | 6.4/110  | 7.7/95   | 8.5/85   | 10.5/70  |

\* $p_n$  - nominal pressure = the highest working pressure allowed without time restriction

\*\* $p_{max}$  - maximum pressure = maximum pressure allowed for a short time - max. 20 s

\*\*\*Before motor selection contact the producer.

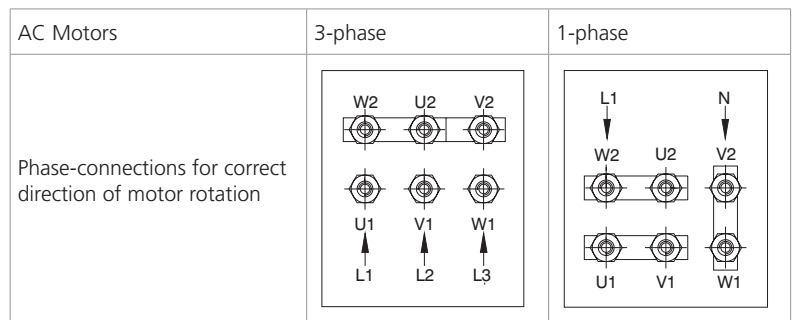

## Type of the Block

**S11.0** Connecting face for valves size 04, 06

**S11.1** Connecting face for valves size 03

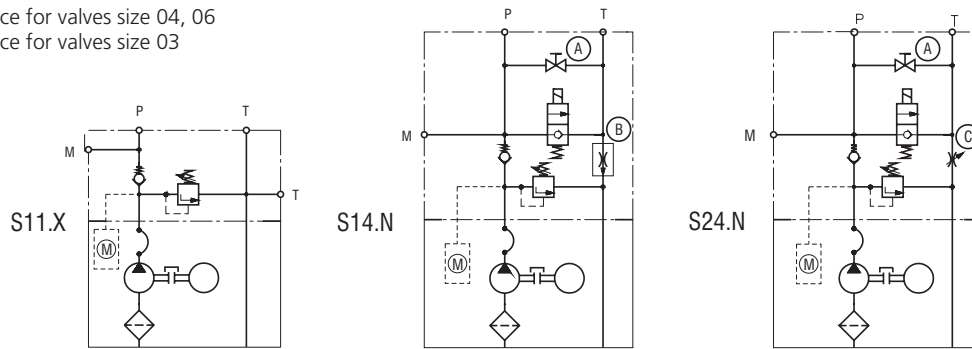

The hydraulic circuit **S11.X** enables the power pack to be used as a simple pressure supply for general applications with the possibility to build up additional hydraulic circuits in the form of horizontal stacking assemblies of the size 04 or 06 (S11.0) or size 03 (S11.1).

The hydraulic circuits **S14.N** and **S24.N** enable the power pack to be used as pressure supply for lifting platforms and other devices, in which the mass of the system provides returning into the basic position. The shut-off valve (A) enables emergency lowering of the device, should a disconnection of the supply voltage occur.

The hydraulic circuit **S14.N** comprises a flow control valve VSK (B) which is adjustable only in a certain range (see catalogue VSK - HA 5121). This valve is accessible from outside of the block. If not otherwise required, a valve VSK is mounted into the block. The stabilized flow rate of this valve corresponds with the respective flow rate of the power pack (see Tab. 1).

The hydraulic circuit **S24.N** comprises a throttle valve VSV1-06 (C) without pressure compensation. This valve is accessible from outside of the block.

**M - start-up module** is suitable for one-phase E-motors (codes 5-9).

Use it if there is no possibility to unload the pressure in the circuit.

## Dimensions in millimeters (inches)

### Steel tank

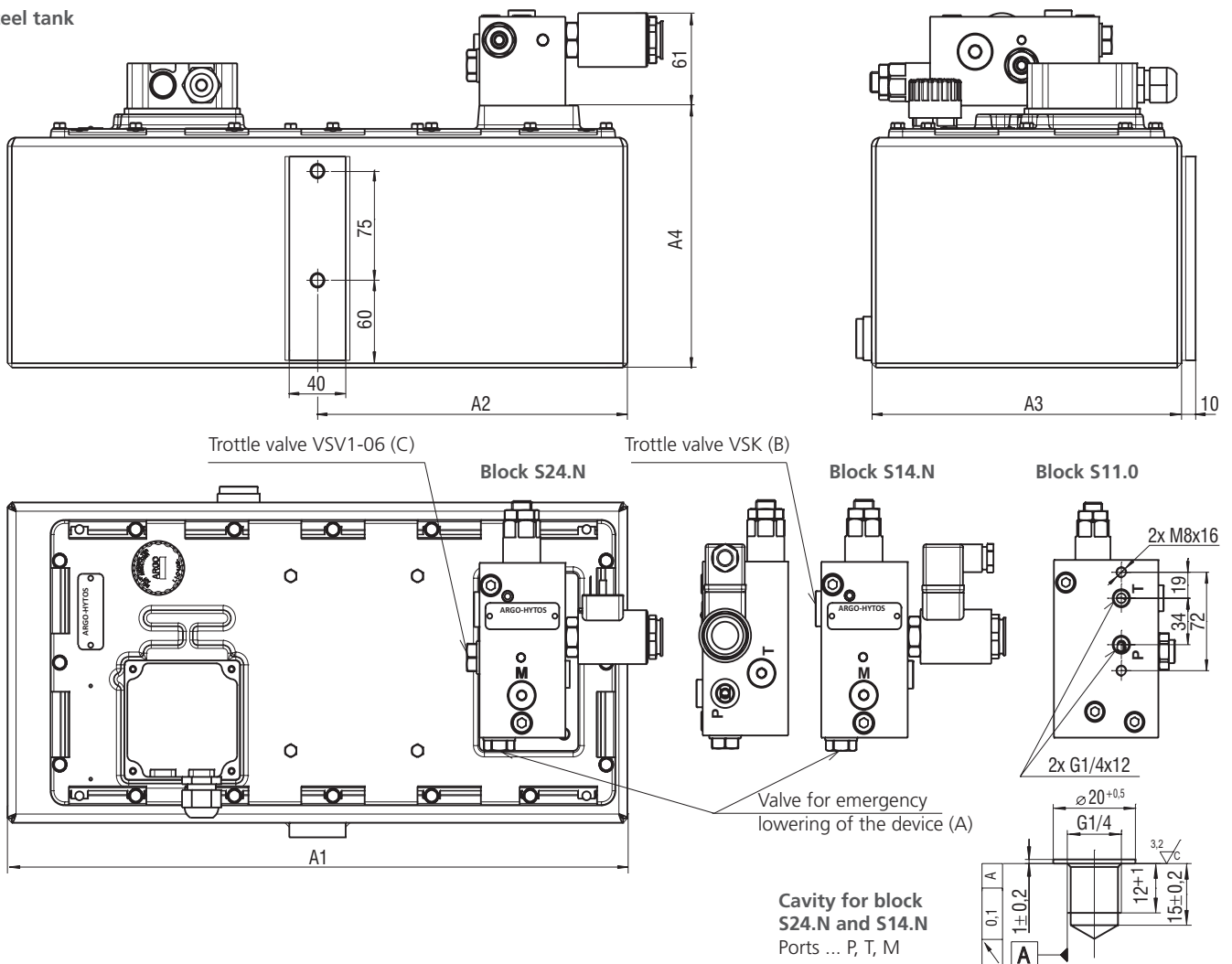

| Code of the tank | Tank Capacity [l] | Working volume [l] | A1 [mm] | A2 [mm] | A3 [mm] | A4 [mm] |
|------------------|-------------------|--------------------|---------|---------|---------|---------|
| 10 (steel)       | 10                | 6                  | 440     | 220     | 220     | 180     |
| 20 (steel)       | 20                | 10                 | 500     | 220     | 260     | 222     |
| 30 (steel)       | 30                | 20                 | 500     | 220     | 260     | 302     |

### Dimensions in millimeters (inches)

Plastic tank  
Plastic tanks are not UV stable. Place the unit in the shade for outdoor application.

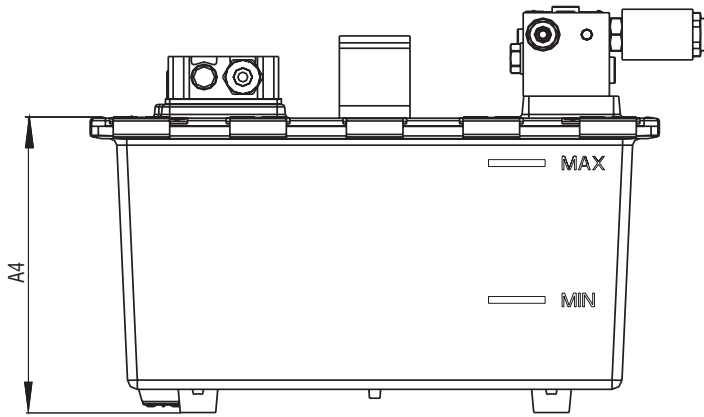

Cavity for block  
S24.N and S14.N  
Ports ... P, T, M

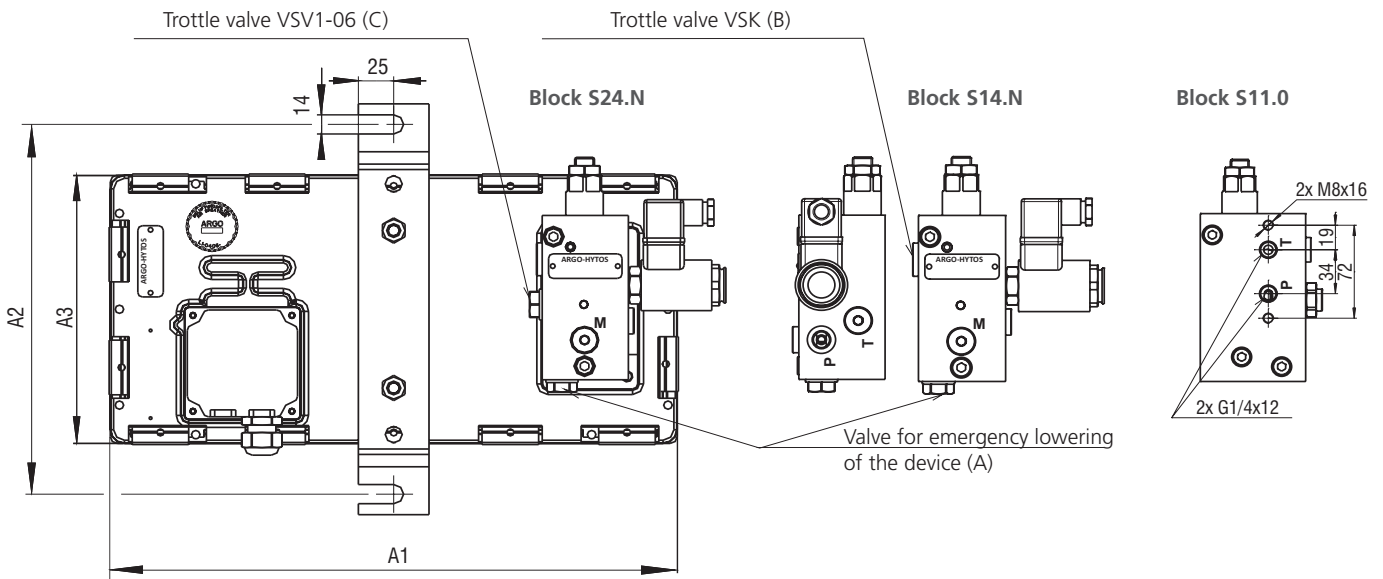
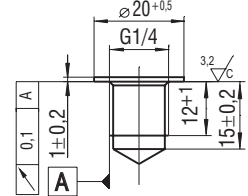

| Code of the tank | Tank Capacity [l] | Working volume [l] | A1 [mm] | A2 [mm] | A3 [mm] | A4 [mm] |
|------------------|-------------------|--------------------|---------|---------|---------|---------|
| 7 (plastic)      | 7                 | 4                  | 401     | 270     | 196     | 215     |

#### Example of horizontal stacking assembly

- possible only with hydraulic circuit S11.0

- possible only with hydraulic circuit S11.1

E - according to the elements used,  
see datasheet of modular elements  
HA 5021, HA 5023, HA 5051, HA 5093

F - Size 04=40 mm  
Size 06=50 mm

G- Size 04=79 mm  
Size 06=92 mm

